

ERL80L 80GHz Radar Level Transmitter

For Liquids in Tanks and Open Channel

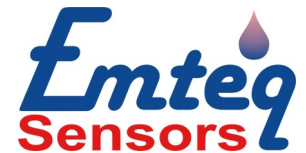

The ERL80L is the sensor for non-contact liquid level measurement in simple applications. It weighs only 200g and is particularly suitable for open channel applications for water and wastewater applications, rain water tanks, flumes and dam level monitoring. This sensor is also well suited to use in tanks and containers.

The Emteq ERL80L Radar Level Sensor represents a significant advancement in the field of electronic measurement devices. Utilising electromagnetic waves, this sensor is adept at detecting targets, specifically engineered for monitoring water & sewage levels. Its capability to interface with smartphones & tablets through Bluetooth technology enhances its user-friendliness, allowing for seamless display & configuration via the dedicated RadarMe App, compatible with both iOS & Android platforms. The sensor's integrated design & high performance chip not only ensure reliability but also facilitate its installation in confined spaces, making it a versatile tool for a wide range of applications. This innovation underscores the growing trend of smart technology integration in industrial & environmental monitoring systems.

Dimensions

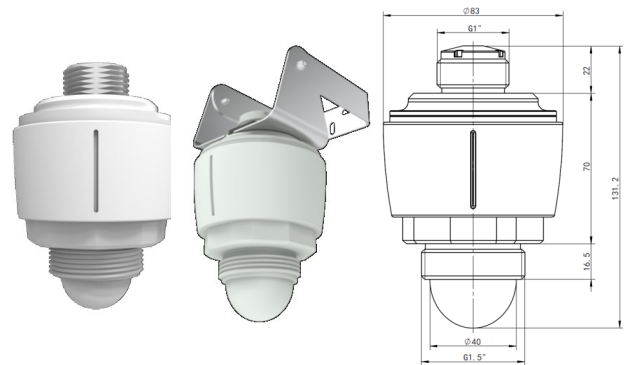

Specifications

Model	ERL80L
Product Type	FMCW Radar Level Transmitter
High frequency:	80GHz
Accuracy:	±2mm (liquid)
Measuring Range	up to 10m (optional up to 30m)
Small angle:	±3.5°
Frequency	77GHz-81GHz
Material	PP (polypropylene)
Connection	Thread, 1" and 1½"
Pressure	-1 to 5 Bar
Process Temperature	-20°C to 70°C
Signal output	4-20mA/Modbus/Bluetooth
Power	Two-wire DC 24V (22V~30V) Four-wire DC (8-36V)
Protection	IP67 Weight:200g



Applications

- Water Treatment
- Sewage Treatment
- Hydrological Monitoring
- Rivers and Channels
- Water/Fuel Tanks
- Chemical Industry
- Petrochemical Process Storage
- Tanks
- Pharmaceutical Industry
- Food and Beverage Industry
- Power Generation
- Process Control
- Mining Industry
- Tank Inventory Monitoring

ERL80L 80GHz Radar Level Transmitter

For Liquids in Tanks and Open Channel

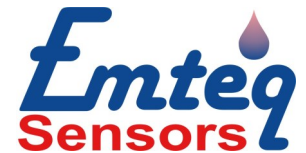

Working Principle

The 80GHz Frequency Modulated Continuous Wave (FMCW) sensor is a sophisticated device used in various applications to measure the level of liquids. It operates by emitting a radar electromagnetic wave from its antenna, which travels until it hits the surface of the liquid & reflects back. The sensor's high-speed chip and specialised acoustic software algorithm then calculate the time interval between the emission & reception of the wave, known as time T. Given that the speed of electromagnetic waves, denoted as C, is constant, the sensor can determine the distance D from the radar antenna to the liquid's surface with precision. This technology is invaluable in industries where accurate level measurement is critical, such as in water treatment facilities, chemical storage and oil tanks, ensuring safety & efficiency in operations. The use of such high-frequency waves allows for greater accuracy & resolution, making the 80GHz FMCW sensor a reliable choice for continuous level monitoring.

Mobile App "RadarMe"

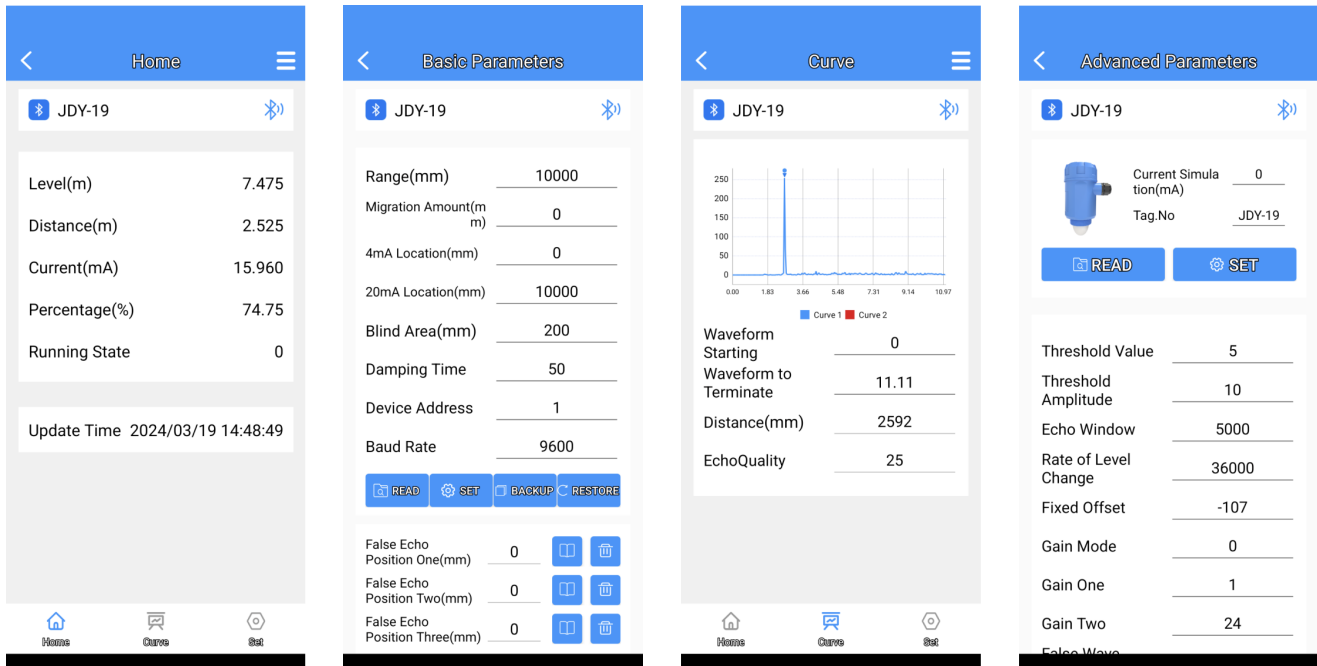

Ordering

ERL80L

80GHz Radar Level Transmitter (PP housing, no display)

Code **Medium Type**
2/4 Two-wire/Four-wire

Code **Measuring Range (m)**
0.2~30 10, 20, 30

Code **Connection**
G G'Thread
F Flange

Code **Temperature**
N -20-70°C

Code **Cable entry**
M M16x1.5(F) G2(M20*1.5)

Code **Electronics**
T Two-wire 4...20mA
M Modbus
B Bluetooth wireless

Common Configuration

ERL80L 2 10 G N M TMB 10 1-20 1 2 5 10 15 20

Process Control Services Pty Ltd, ABN 22 054 111 018

V24b

Ph: Sydney (02) 9319 1808, Brisbane (07) 3299 7881, Melbourne (03) 9859 0157, Auckland (09) 525 3425
eMail sales@pcspl.com.au, Web www.pcspl.com.au